

JOB \_\_\_\_\_ ITEM # \_\_\_\_\_ QTY # \_\_\_\_\_

## MODEL NUMBER:

- 7QT-D-T-R
- 7QT-OD-T-R
- 11QT-D-T-R
- 11QT-OD-T-R

## WARRANTY

- One year parts and labor. Warranty is detailed on inside front cover of the price list.

## SHIPPING INFORMATION

- Shipping Weight:9
- Shipping Cubic Feet:1.2
- Freight Class:92.5



## 7QT-D-T-R

Heavy-duty electric Round food storage receptacles are designed for drop-in (top mounting ) installation into a custom counter fixture. Designed for wet or dry usage, these units may be installed in metal or wood countertops.\*

## STANDARD FEATURES

- Top mounting flange and food well is constructed of one piece, deep drawn, stainless steel
- Furnished with a circular strip heater rated at .3KW for energy efficiency
- Controlled by an infinite heat switch
- Easy to read ON/OFF indicator light
- Adjustable temperature controls
- Lead wires are 48" long for easy installation
- Units with drain have a 3/4" drain pipe with screen as standard

SPEC D-4

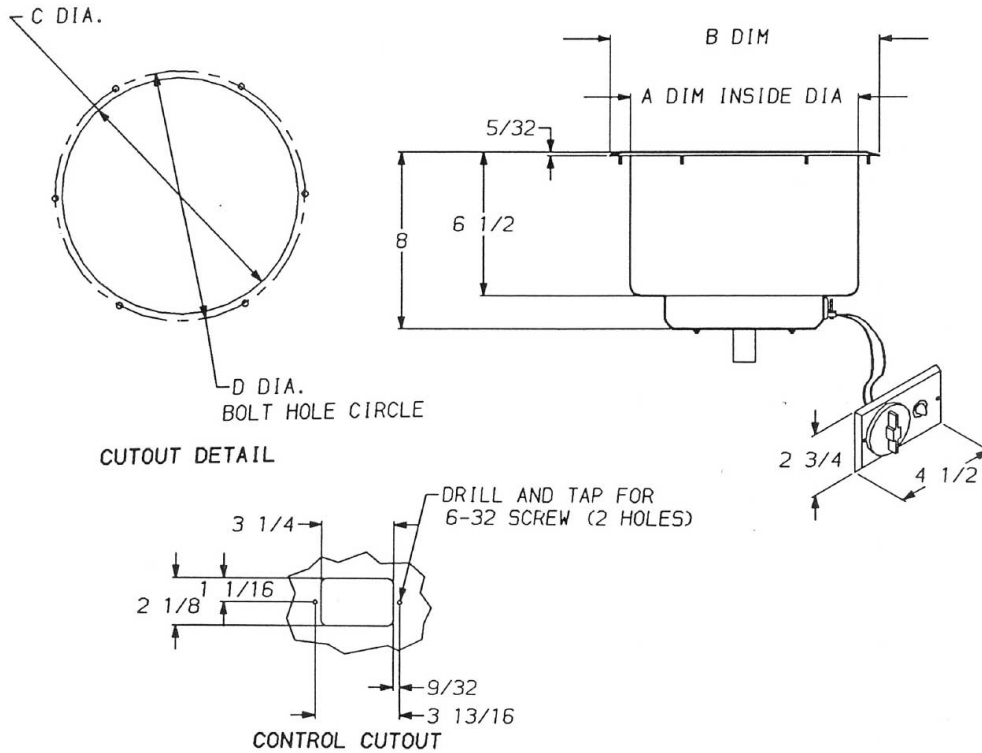

Model#	A	B	C	D	Amperage 120V	Amperage 208V	Amperage 240V	Wattage	Ship Wt. (lbs)
7QT-D-T-R	8-3/8" diameter	10-7/32"	8-3/16" diameter	9-7/16"	2.5	1.4	1.3	300	9
7QT-OD-T-R	8-3/8" diameter	10-7/32"	8-3/16" diameter	9-7/16"	2.5	1.4	1.3	300	9
11QT-D-T-R	10-3/8" diameter	12-9/32"	10-11/16" diameter	11-5/16"	2.5	1.4	1.3	300	10
11QT-OD-T-R	10-3/8" diameter	12-9/32"	10-11/16" diameter	11-5/16"	2.5	1.4	1.3	300	10

## SPEC D-4

# PIPER

The Food-Focused Equipment Company

300 S. 84th Avenue | Wausau, WI 54401  
Phone: 800-544-3057 | Fax: 715-842-3125  
[www.piperonline.net](http://www.piperonline.net)

**LIMITED WARRANTY: PIPER PRODUCTS** warrants to the original purchaser parts and labor for a period of twelve (12) months from the date of purchase. See manufacturer's complete warranty for details.

It is our policy to build equipment which is design certified by companies that have been accredited at the Federal Level by the Occupational Safety and Health Agency (OSHA) and ANSI as a National Recognized Testing Laboratory. These companies include CSA International, Underwriters Laboratories, and the National Sanitation Foundation. However, a continuing program of product improvement makes it necessary to submit new models to the agencies as they are developed. Consequently, all models may not bear the appropriate labels at all times. We reserve the right to change specifications and product design without notice. Such revisions do not entitle buyer to corresponding changes, improvements, additions or replacements for previously purchased equipment. Information is not for design purposes.