

JOB \_\_\_\_\_ ITEM # \_\_\_\_\_ QTY # \_\_\_\_\_

### MODEL NUMBER:

- 411-1147     411-1149     411-1151  
 411-1148     411-1150     411-1152

### DIMENSIONS:

- 411-1147 - 23.5" W
- 411-1148 - 45" W
- 411-1149 - 65.75" W
- 411-1150 - 23.5" W
- 411-1151 - 45" W
- 411-1152 - 65.75" W

### STANDARD FEATURES

- Available in either aluminum or stainless steel
- Accommodates most non-insulated and insulated domes or underbases
- Mobile
- Variety of capacities
- Plastic racks and insert come standard
- Frame and cross supports are 1" square aluminum or 16-gauge square stainless steel tubing
- Fully welded frame requires no assembly
- 1" x 1" angle shelves welded to 1" square tubing
- Universal plastic wash racks have a coated wire rack insert to hold the domes

### HEAVY-DUTY CASTERS

- 5" diameter x 1 1/4" wide swivel sealed wheels on Colson® rigs
- Delrin bearing, each with 350 lb. capacity
- Maximum resistance to chemicals, acids, bases, alcohol, water and steam
- Maximum low temperature flexibility or superior performance even in freezing temperatures

### WARRANTY

One year parts and labor. Warranty is detailed on inside front cover of the price list.

#### COMMON OPTIONS

<input type="checkbox"/>	411-1153	Universal Wash Rack Assembly
<input type="checkbox"/>	R	Rotating Bumper (Adds 5" to overall length and width)
<input type="checkbox"/>	WB	Two locking casters
<input type="checkbox"/>	Y4	Polyurethane 4
<input type="checkbox"/>	Y5	Polyurethane 5



411-1151 or 190-1077

The Piper Dome Storage Carts are a practical way to store and dry plastic, plastic single wall and most insulated style domes. The molded underbases can be stored in the same fashion.

The storage carts have individual racks to hold dome covers and underbases between warewashing, storage and makeup areas with minimum handling. The Piper Storage Cart comes complete with the universal dish rack and wire insert.

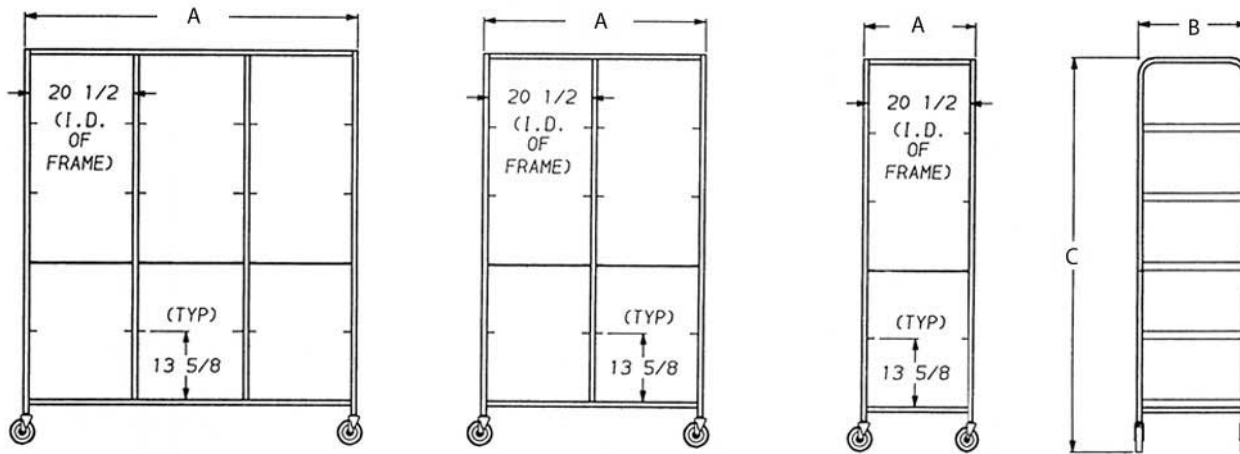

Model #	Description	Capacity	(A) Width	(B) Length	(C) Height
411-1147	Aluminum	50 Domes	23.5"	22"	78"
411-1148	Aluminum	100 Domes	45"	22"	78"
411-1149	Aluminum	150 Domes	65.75"	22"	78"
411-1150	Stainless Steel	50 Domes	23.5"	22"	78"
411-1151	Stainless Steel	100 Domes	45"	22"	78"
411-1152	Stainless Steel	150 Domes	65.75"	22"	78"

Allow an extra 1.5" for caster protection on overall dimensions.

## SPEC F-8

# PIPER

The Food-Focused Equipment Company

300 S. 84th Avenue | Wausau, WI 54401  
Phone: 800-544-3057 | Fax: 715-842-3125  
[www.piperonline.net](http://www.piperonline.net)

**LIMITED WARRANTY: PIPER PRODUCTS** warrants to the original purchaser parts and labor for a period of twelve (12) months from the date of purchase. See manufacturer's complete warranty for details.

It is our policy to build equipment which is design certified by companies that have been accredited at the Federal Level by the Occupational Safety and Health Agency (OSHA) and ANSI as a National Recognized Testing Laboratory. These companies include CSA International, Underwriters Laboratories, and the National Sanitation Foundation. However, a continuing program of product improvement makes it necessary to submit new models to the agencies as they are developed. Consequently, all models may not bear the appropriate labels at all times. We reserve the right to change specifications and product design without notice. Such revisions do not entitle buyer to corresponding changes, improvements, additions or replacements for previously purchased equipment. Information is not for design purposes.